



SF108
v1.1
SF108 10-port switch for 8 IP cameras



Edition: 3 from 17.08.2017
 Supercedes the edition: 2 from 09.01.2017

EN

Features:

- Switch 10 ports
- 8 PoE ports 10/100Mb/s, (1÷8 ports) (data and power supply)
- 2 ports 10/100/1000 Mb/s (G1/TP, G2/TP ports) (UpLink)
- 2 ports 10/100/1000Mb/s SFP (G1/SFP, G2/SFP ports)
- 15,4W for each PoE port, supports devices compliant with the IEEE802.3af standard
- Supports auto-learning and auto-aging of MAC addresses (1K size)
- LED indication
- The PSD 480250 48VDC/2,5A/120W max. power supply desktop type included
- Additional assembly elements
- warranty – 2 year from the production date

Example of use.

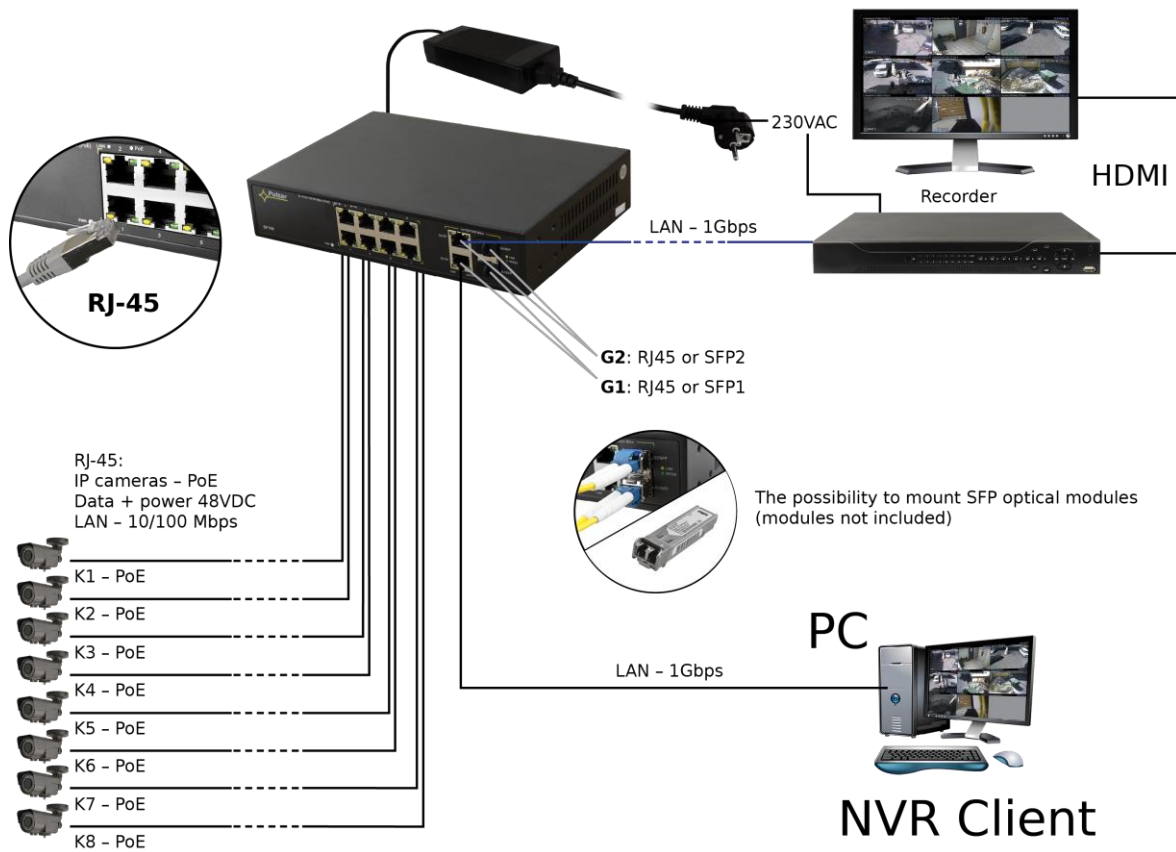

1. Technical description.

1.1. General description.

SF108 is a 10- port PoE switch designed to supply IP cameras operating in IEEE 802.3af standard. Automatic detection of any devices powered in the PoE standard is enabled at the 1 – 8 ports of the switch. The G1/TP and G2/TP ports are used for connection of another network device via RJ45 connector. The switch is fitted with SFP slots (marked as G1/SFP and G2/SFP); the use of fiber optic module (GBIC) allows fiber optic transmission. The operating status of the device (described in the table below) is displayed on the LED display on the front panel. The PoE technology ensures a network connection and reduces installation costs by eliminating the need to supply a separate power cable for each device. This method allows supplying other network devices, such as IP phone, wireless access point or router.

1.2. Block diagram.

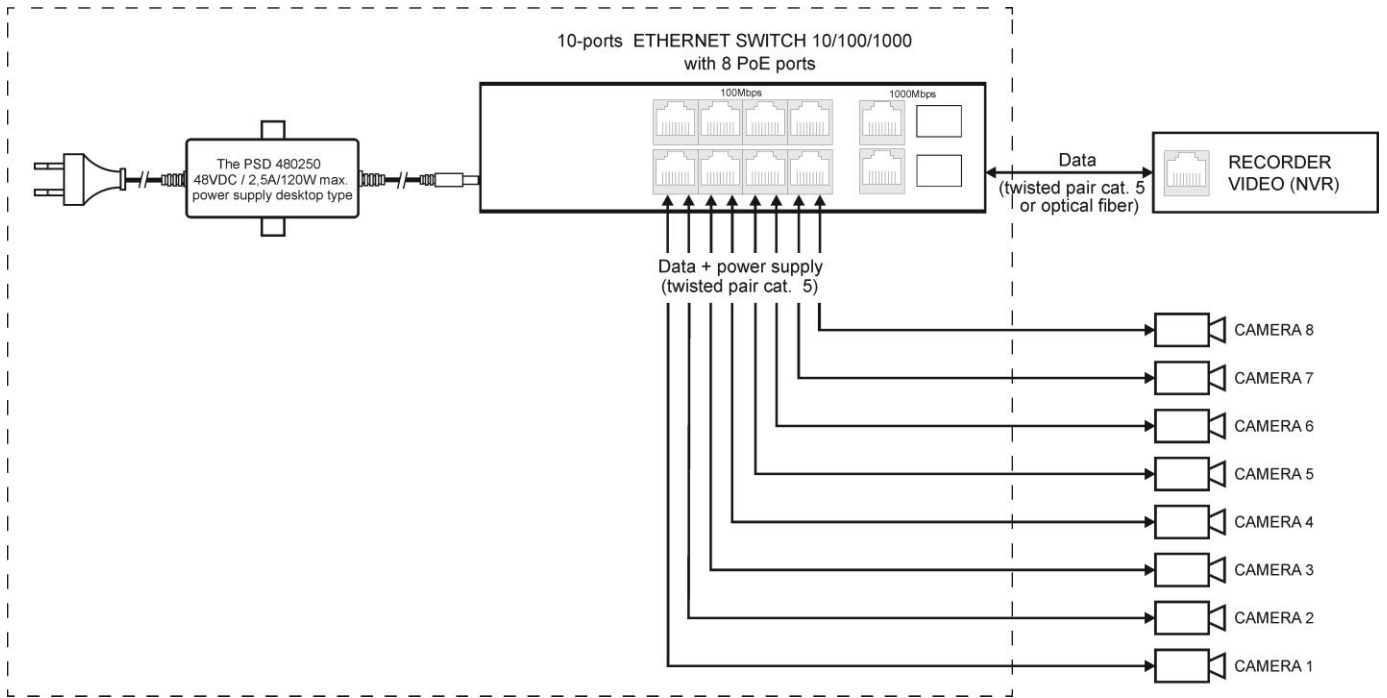

Fig. 1. Block diagram.

1.3. Description of components and connectors.

Table 1. (see Fig. 2)

Element no. (Fig. 2)	Description
[1]	8 x PoE port (1÷8)
[2]	2 x UPLINK ports (G1/TP, G2/TP)
[3]	2 x UPLINK ports (G1/SFP, G2/SFP)
[4]	Power Socket of the 48V DC

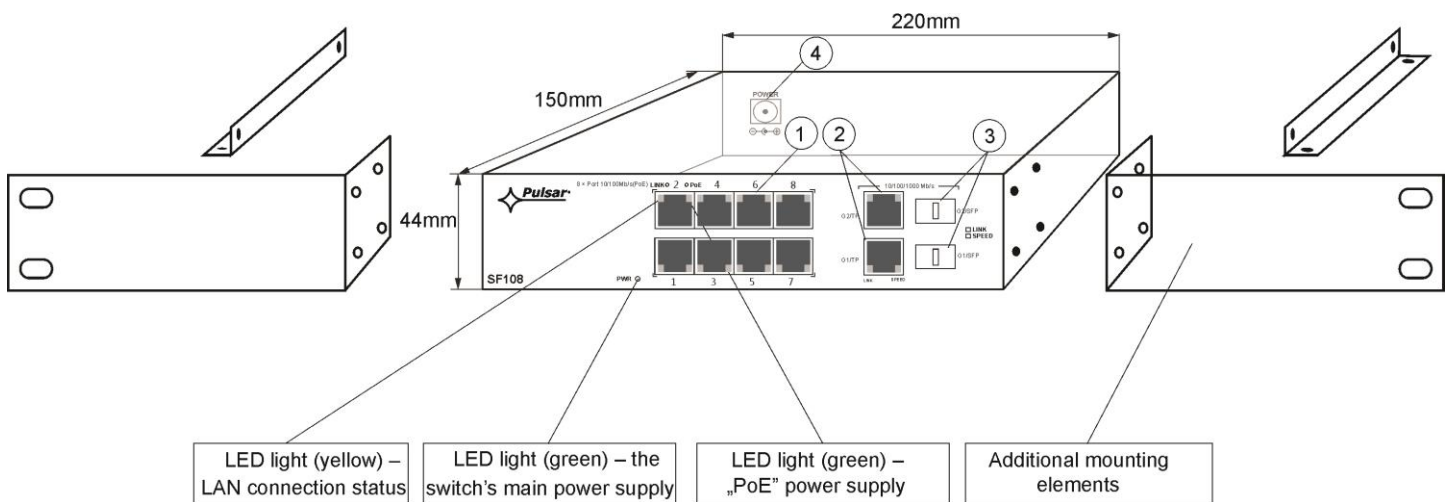

Fig. 2. The view switch'a.

1.4. Technical parameters (table 2.)

Table 2.

Ports	8 x PoE (10/100Mb/s) (RJ-45) 2 x UPLINK (10/100/1000Mb/s) (RJ-45) 2 x UPLINK (10/100/1000Mb/s) (SFP) with connection speed auto-negotiation and MDI/MDIX Auto Cross)
PoE power supply	IEEE 802.3af (1+8 ports), 48VDC / 15,4W at each port * Used pairs 4/5 (+), 7/8 (-)
Protocols, Standards	IEEE802.3, 802.3u, 802.3x CSMA/CD, TCP/IP
Forwarding rate	10BASE-T: 14880pps/port 100BASE-TX: 148800pps/port
Bandwidth	1,6Gbps
Transmission method	Store-and-Forward
Optical indication of operation	Switch power supply Link PoE Status
Power supply	90 ÷ 264VAC 50÷60Hz / 0,6A 230VAC max. the PSD 480250 48VDC/2,5A/120W max. power supply desktop type
Operating conditions	temperature -10°C ÷ 40°C, relative humidity 20% - 90%, no condensation
Dimensions (W x H x D)	220 x 44 x 150 [mm]
Additional equipment	plate to be fixed surface, bracket for Rack 19"
Net/gross weight	1,7/1,9kg
Protection class EN 60950-1:2007	I (first)
Storage temperatur	-20°C ÷ 60°C
Declarations	CE

* The given value of 15,4W per port is the maximum value. The total power consumption should not exceed 96W when all PoE ports are being used.

2. Installation.

2.1. Requirements.

The unit should be mounted in confined spaces, in accordance with the 2nd environmental class, with normal relative humidity (RH=90% maximum, without condensation) and temperature from -10°C to +40°C. Ensure the free flow of air around the unit. The PSU shall work in a vertical position that guarantees sufficient convectonal air-flow through ventilating holes of the enclosure.

The switch load balance should be done before installation. The given value of 15,4W per port is the maximum value referring to a single output. The total power consumption should not exceed 96W when all PoE ports are being used. The increased demand for power is particularly evident in the case of cameras with heaters or infrared illuminators - when launching these features, the power consumption increases rapidly, which may adversely affect the operation of the switch. As the device is designed for a continuous operation and is not equipped with a power-switch, therefore an appropriate overload protection in the power supply circuit should be provided. The electrical system shall be made in accordance with applicable standards and regulations.

2.2. Installation procedure.

1. Connect switch to the PSD480250 48VDC power supply unit desktop type.
2. Connect the power supply to the AC 230V socket.
3. Connect the camera wires to the RJ45 connectors (PoE connectors (sockets RJ45 from 1 to 8)).
4. Connect the remaining LAN devices to RJ45 connectors or SFP sockets (G1/TP and G1/SFP or G2/TP and G2/SFP)
CAUTION! G1/TP and G1/SFP or G2/TP and G2/SFP connectors can not operate simultaneously.
5. Check the optical indication of switch operation (see Table 3).

Connection schemes

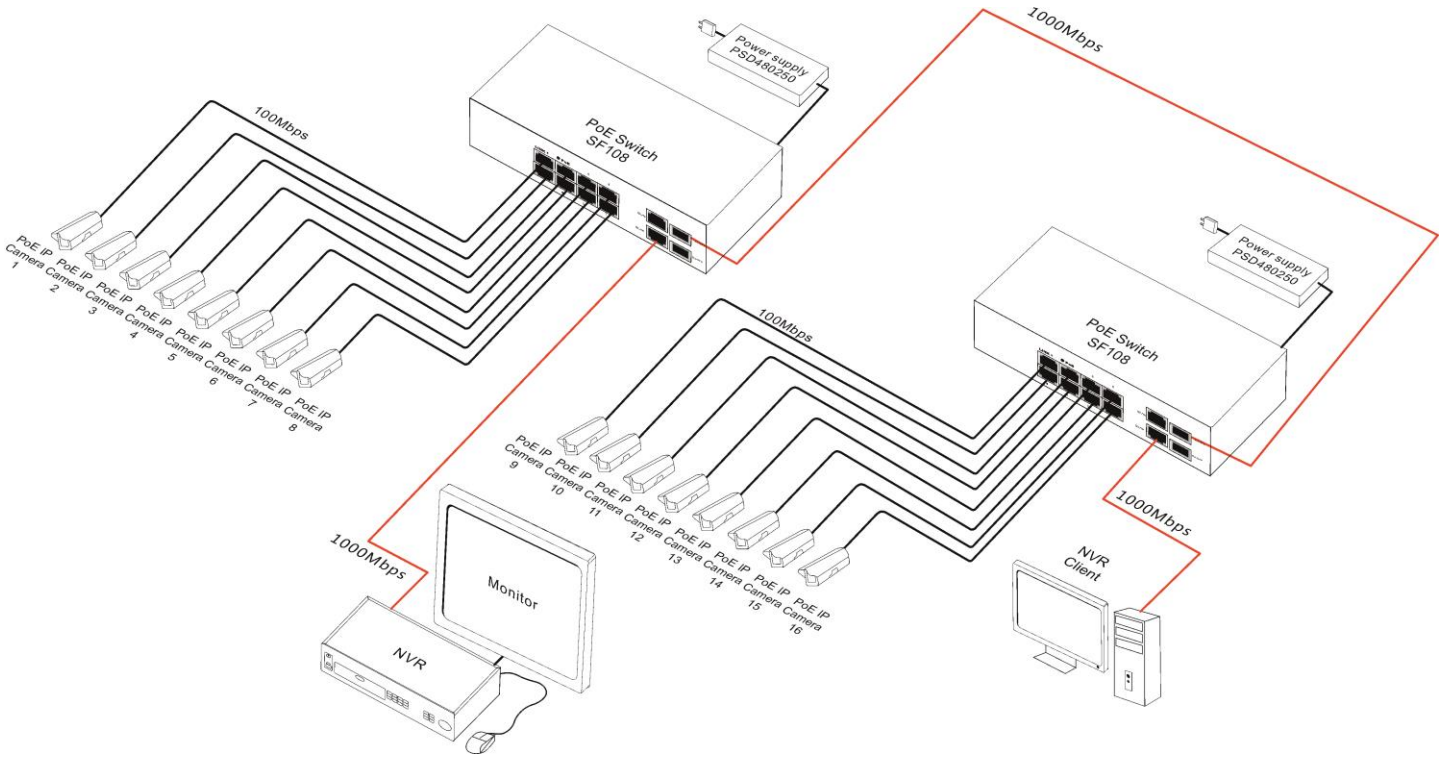



3. Operation indication (see table 3)

Table 3. Operation indication



OPTICAL INDICATION OF THE SWITCH'S POWER SUPPLY

<p>GREEN LED LIGHT (Power) Indication of the switch's power supply</p>	<p>PWR </p>	<p>OFF – no power supply of the switch ON – power supply on, normal operation</p>
---	---	---

OPTICAL INDICATION AT THE PoE PORTS (1÷8)

<p>GREEN LED LIGHT (PoE) Indication of the PoE power supply at the RJ45 ports</p>		<p>OFF - no power supply at the RJ45 port (the device is not connected or not compliant with the IEEE802.3af standard) ON – supply Blinking – short-circuit or output overload</p>
<p>YELLOW LED LIGHT (LINK) The connection status of LAN devices, 10MB/s or 100Mb/s and data transmission</p>		<p>OFF - no connection ON - the device is connected; 10Mb/s or 100Mb/s Blinking – data transmission</p>

OPTICAL INDICATION AT THE UPLINK PORT (G1/TP, G2/TP, G1/SFP, G2/SFP)

<p>YELLOW LED LIGHT (LINK)</p>		<p>OFF - no connection ON - the device is connected Blinking – data transmission CAUTION! The operating status of the G1/TP, G1/SFP, G2/TP and G2/SFP slots is shown on the LEDs located near the RJ45 connector (see below). CAUTION! G1/TP and G1/SFP or G2/TP and G2/SFP sockets can not operate simultaneously. These are COMBO type sockets.</p>
<p>GREEN LED LIGHT (SPEED)</p>		<p>OFF – connection 10Mb/s or 100Mb/s ON - connection 1000Mb/s CAUTION! The operating status of the G1/TP, G1/SFP, G2/TP and G2/SFP slots is shown on the LEDs located near the RJ45 connector (see below). CAUTION! G1/TP and G1/SFP or G2/TP and G2/SFP sockets can not operate simultaneously. These are COMBO type sockets.</p>



WEEE LABEL

Waste electrical and electronic equipment must not be disposed of with normal household waste. According to the European Union WEEE Directive, waste electrical and electronic equipment should be disposed of separately from normal household waste.

Pulsar

Siedlec 150, 32-744 Łapczyca, Poland
Tel. (+48) 14-610-19-40, Fax. (+48) 14-610-19-50
e-mail: biuro@pulsar.pl, sales@pulsar.pl
http:// www.pulsar.pl, www.zasilacze.pl